

# MOX-SPI-6D28



## Surface Mount Shielded Power Inductors

MoxiE's SPI-6D28 series of surface mount shielded power inductors are widely used in PDA's, notebooks, LCD televisions and digital cameras. MoxiE offers a ultra low profile magnetically shielded package that offer high inductance & high power.

### Features:

- Low Cost.
- Operating Temperature: -30°C to +85°C.
- Available Tolerances:  $\pm 20\%$  &  $\pm 30\%$ .
- RoHS Compliant.
- Magnetically Shielded Applications.



## NOTES

---

---

---

---

---

---

---

---

---

---



## MECHANICAL DIMENSIONS

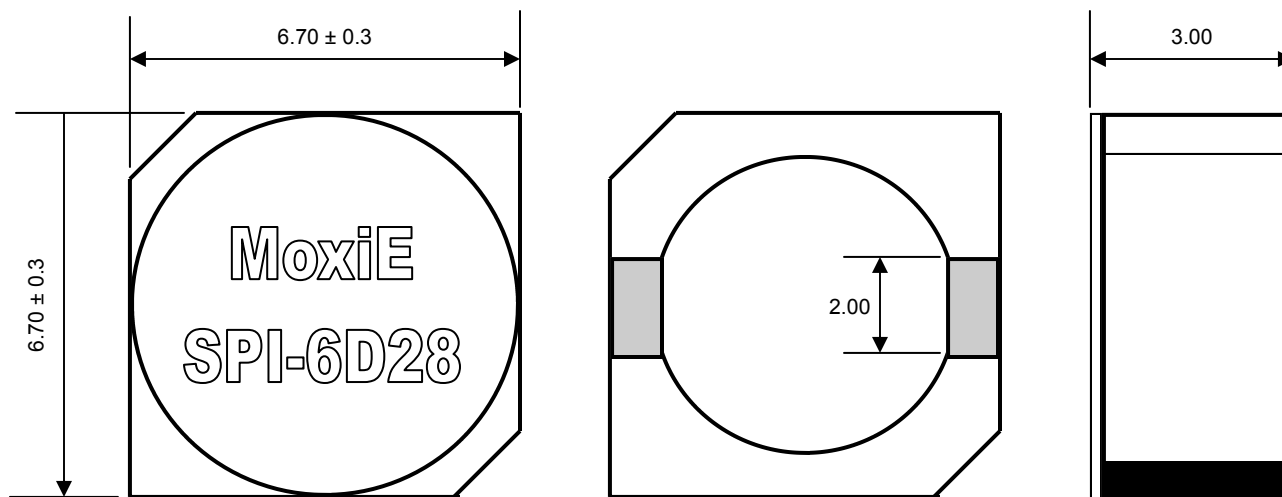



## LANDING PATTERN & SCHEMATIC

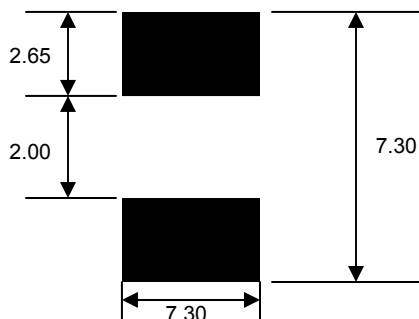
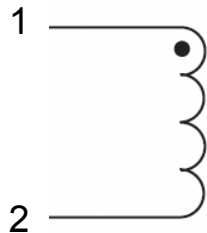

## ELECTRICAL SPECIFICATIONS

Part Number	Inductance (µH)	Tolerance (%)	DCR (mΩ) Maximum	Rated Current (A)	L Test Frequency
MOX-SPI-6D28-3R0T	3.0	30% (T)	24	3.00	100 kHz
MOX-SPI-6D28-3R9T	3.9	30% (T)	27	2.60	100 kHz
MOX-SPI-6D28-5R0T	5.0	30% (T)	31	2.40	100 kHz
MOX-SPI-6D28-6R0T	6.0	30% (T)	35	2.25	100 kHz
MOX-SPI-6D28-7R3T	7.3	30% (T)	54	2.10	100 kHz
MOX-SPI-6D28-8R6T	8.6	30% (T)	58	1.85	100 kHz
MOX-SPI-6D28-100T	10.0	30% (T)	65	1.70	100 kHz
MOX-SPI-6D28-120T	12.0	30% (T)	70	1.55	100 kHz
MOX-SPI-6D28-150T	15.0	30% (T)	84	1.40	100 kHz
MOX-SPI-6D28-180T	18.0	30% (T)	95	1.32	100 kHz
MOX-SPI-6D28-220T	22.0	30% (T)	128	1.20	100 kHz
MOX-SPI-6D28-270T	27.0	30% (T)	142	1.05	100 kHz
MOX-SPI-6D28-330T	33.0	30% (T)	165	0.97	100 kHz
MOX-SPI-6D28-390T	39.0	30% (T)	210	0.86	100 kHz
MOX-SPI-6D28-470T	47.0	30% (T)	238	0.80	100 kHz
MOX-SPI-6D28-560T	56.0	30% (T)	277	0.73	100 kHz
MOX-SPI-6D28-680T	68.0	30% (T)	304	0.65	100 kHz
MOX-SPI-6D28-820T	82.0	30% (T)	390	0.60	100 kHz
MOX-SPI-6D28-101T	100.0	30% (T)	535	0.54	100 kHz



## MOX-SPI-6D28 ENGINEERING NOTES

- Measuring Frequency (L) 100 kHz
- Available Tolerances: K = ±10%, M = ±20%, T = ±30%
- RoHS Compliant.
- DC current at which the inductance drops 35% (typical) from its value without current.
- Temperature rise of 40°C maximum.
- Magnetically shielded to prevent noise radiation.
- MoxiE Inductor Corporation specifications are subject to change without notice.